



**TECHNICAL DESCRIPTION OF SELF-CLEANING TOILET**  
**Mod. TMAX - January 2021**





## Table of contents

---

<b>SELF CLEANING TOILET TMAX SERIES.....</b>	<b>3</b>
<b>AVAILABLE MODELS .....</b>	<b>5</b>
base Model.....	5
Model Milano .....	6
Model Venezia.....	7
Model Amsterdam .....	8
<b>INSIDE THE TOILET .....</b>	<b>9</b>
<b>INSTALLATION PROCEDURES.....</b>	<b>11</b>
<b>TECHNICAL SPECIFICATIONS.....</b>	<b>12</b>
<b>INTERNAL FINISH AND EQUIPMENT.....</b>	<b>13</b>
<b>EQUIPMENT .....</b>	<b>15</b>
WATER SYSTEM .....	15
PNEUMATIC SYSTEM.....	15
ELECTRIC SYSTEM.....	15
DISPOSAL SYSTEM .....	16
HEATING/EMPTYING SYSTEM .....	16
SAFETY .....	17
USER DETECTION SYSTEM.....	17
PNEUMATIC SLIDING DOOR.....	17
✓ PT-LINE .....	18
PT-CALL .....	19
WASHBASIN WITH SHARP-PROOF SAFETY SYSTEM .....	19
EMERGENCY PUSH BUTTONS (SOS).....	19



EMERGENCY LIGHT .....	19
FIREPROOF AND VANDAL-PROOF INDOOR COMPONENTS .....	19
USAGE TIME LIMIT SYSTEM .....	19
PT-HELP.....	20
PT-HEALTH.....	20
<b>PLUS TECHNOLOGY® .....</b>	<b>23</b>
main features .....	23
<b>WASH AND DISINFECTION SYSTEM.....</b>	<b>24</b>
WASH, DISINFECTION AND DRYING OF TOILET BOWL .....	24
wash of toilet seat and walls:.....	24
dynamic wash of the toilet seat.....	24
washing of walls.....	25
wash of washbasin bowl with high-pressure nozzle.....	25
wash and drying of floors WITH Lava;-Tergipavimento® .....	25
PERFUMING SYSTEM PT fresh®.....	28
Night-time total Disinfection Cycle- DCN-ECO3®.....	28
<b>CYCLE OF USE .....</b>	<b>29</b>
<b>OPTIONS .....</b>	<b>31</b>
<b>EQUIPMENT PROVIDED .....</b>	<b>32</b>
external FEATURES:.....	32
OPTIONS .....	32
<b>TECHNICAL DATA SHEET .....</b>	<b>32</b>



## SELF CLEANING TOILET TMAX SERIES

**TMAX** is an **OUTDOOR AUTOMATIC SELF-CLEANING TOILET**, designed and built to combine **design and technology**, while guaranteeing **safety, perfect sanitization and drying** after every use. This model meets all the highest aesthetic and functional expectations of modern cities: the synergy between the high resistance of its components and the flexibility of external finishes allows a perfect integration into every urban setting.

Furthermore, due to the most recent restrictions and recommendations in terms of personal protection and hygiene, the whole range of our self-cleaning toilets is now complying the regulations issued, thanks to an additional **PT-Health** kit that allows the use of the toilet in total safety.

The user does not need to touch any part of the toilet, since all controls are touchless (entrance, exit, paper distribution, flush, soap, water, hand-dryer), thus ensuring hygiene, safety, and reliability.

This kit joins the already available **DCN Eco®** disinfection system, that already was a key feature of Plus Technology®

**Management, cleaning and PLUS® disinfection** guarantee a **perfect wash, sanitation, and drying of the toilet**. A **combined patented system** washes and dries the bowl top, and the **Lava;-Tergipavimento®** patented system washes and dries the floor while eliminating any possible remain from the floor; the whole system has an **extremely low water consumption** (about 16 lt. per washing cycle). This toilet is suitable for highly populated areas, which need extremely high standards of hygiene and disinfection.

The toilet has a rectangular layout: external size is approx. m. m. 2,10 x 3,04 with total height of block of m 2.60.

Internal size is m. 1.65x2.00; the layout of equipment and accessories allows the access to users with disabilities on wheelchair, in compliance with local regulations.

The following are among the main features of Plus Technology®:

- ✓ PLUS® technology washing, disinfection and cleaning thanks to the **Lava;-Tergipavimento®** system
- ✓ External structure made of a **reinforced concrete single block**: vandal-proof, fireproof, anti-graffiti
- ✓ The **technical room** is **accessible from outside** only, to prevent vandal acts, and protects the safety of users.



- ✓ **Internal HPL** cladding, without joints, vandal-proof, fireproof, anti-graffiti
- ✓ Pneumatic, recessed, stainless-steel **sliding door** (that works also in case of power cuts)
- ✓ **User detection system** by means of electronic weight sensors mounted on the floor to set a minimum and maximum weight. In case the weight is under the pre-set (e.g. in case a child enters the room) the door does not close, but the toilet works; in case the detected weight is above the pre-set, the system detects a misuse and the toilet gets in out-of-order status, and cannot be used
- ✓ Large washbasin with patented **anti-syringe system**
- ✓ **SOS push** buttons for emergency calls and **PT-Call® bidirectional emergency call system**
- ✓ Exclusive PTMatic **DCN-ECO3®** night disinfection system that does not release pollutants in the environment.
- ✓ Access control by touchless sensor, multi-coin cash box, banknotes reader, credit card, or contactless ID card with time scheduling option
- ✓ Access for users with disabilities in accordance with local regulations
- ✓ **Self-diagnosis system** in case of fault and real-time remote alarm via GSM to mobile-phone or computer.



## AVAILABLE MODELS

### BASE MODEL

The “Base Model” is characterized by the following specifications:

- ✓ Reinforced concrete single block, with side abutments
- ✓ Finishing with dark grey aluminium profile;
- ✓ Front and back wall coloured with beige RAL 1015;
- ✓ Side abutments are grey;

#### TMAX – Basic Model: external view



#### T MAX – Basic Model: layout

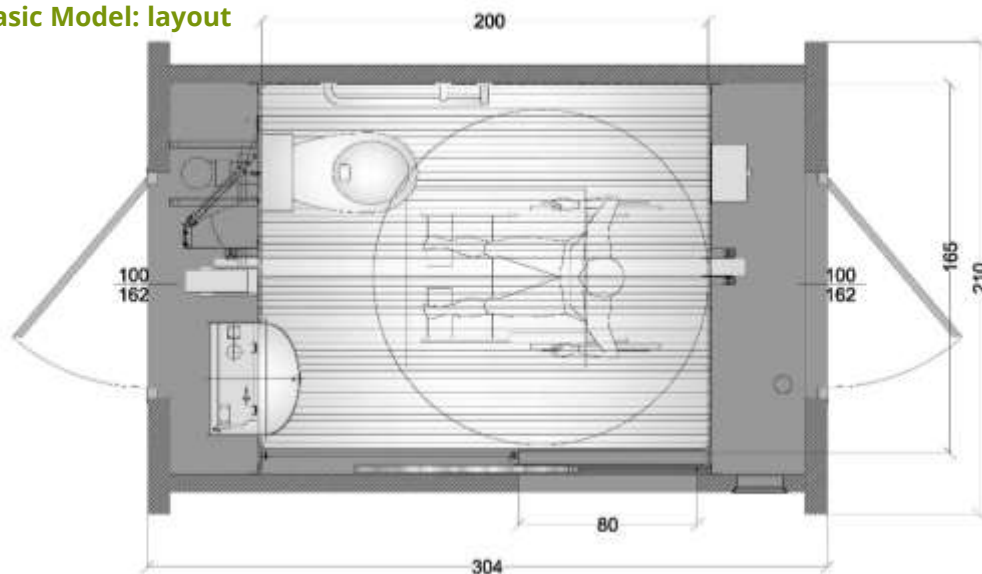



## MODEL MILANO

The “Milano Model” is characterized by the following specifications:

- ✓ Single block in reinforced concrete, with side abutments;
- ✓ Front and back ornamental stainless-steel flashing, with laser-cut pictograms and external LED lighting;
- ✓ Front and back walls decorated with horizontal grooves (beveling), painted beige (other solutions are available on request);
- ✓ Side walls are painted dark grey;

### TMAX - Model Milano: external view



### TMAX - Model Milano: layout

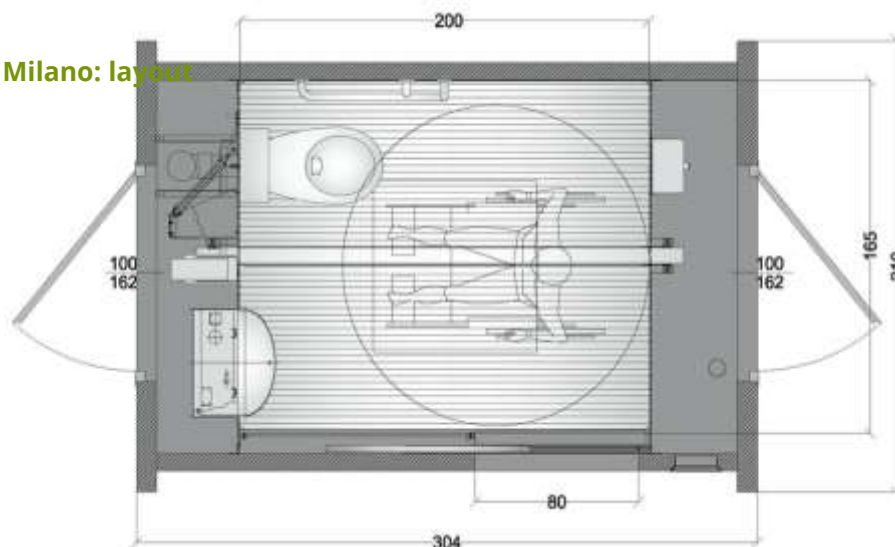





## MODEL VENEZIA

The "Venezia Model" is characterized by the following specifications:

- ✓ Reinforced concrete single block with side abutments;
- ✓ "Venezia-style" perimeter flashing;
- ✓ WC indication;
- ✓ External finish of front and back walls with 30x60 cm tiles;

### TMAX - Model Venezia



TMAX - Model Venezia: external view

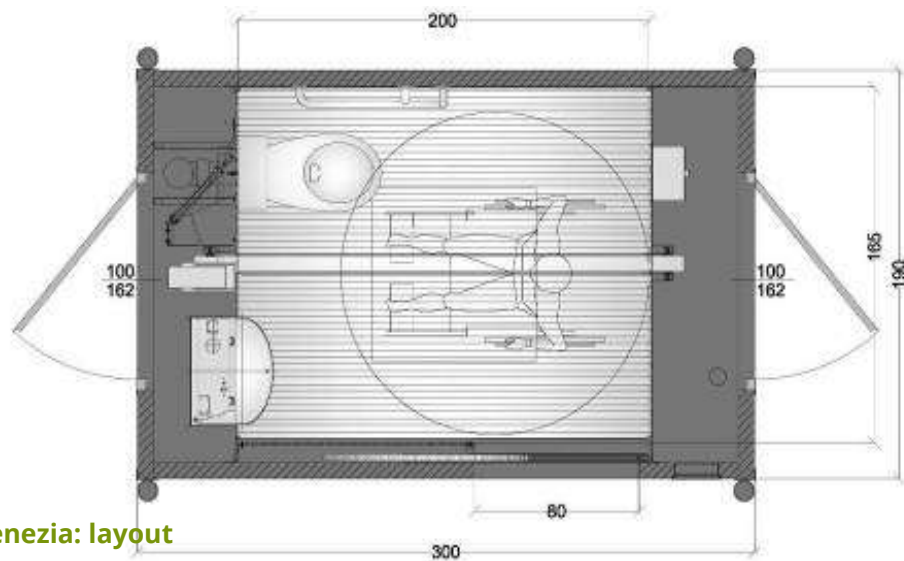

TMAX - Model Venezia: layout



## MODEL AMSTERDAM

The “Venezia Model” is characterized by the following specifications:

- ✓ Reinforced concrete block;
- ✓ Perimeter ornamental stainless-steel flashing, with laser-cut pictograms;
- ✓ External LED lighting;
- ✓ Walls decorated with horizontal motives (bevelling);



**TMAX - Model Amsterdam: external view**

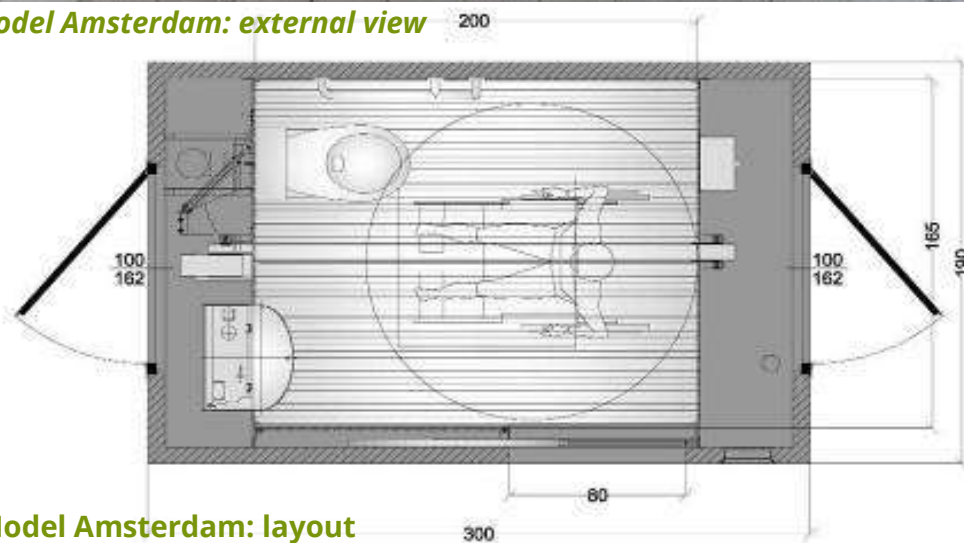

**TMAX - Model Amsterdam: layout**

*\*the solutions shown in the pictures have Italian sizes*



## INSIDE THE TOILET





NIGHT DISINFECTION  
DCN-ECO3®

TIMER

TOUCHLESS EXIT BUTTON



SOS LOWER BUTTON

RECESSED TRASH BIN  
(coming soon: touchless  
opening)



## INSTALLATION PROCEDURES

The installing procedure and setting of the toilet is extremely quick and easy.

PTMatic supplies the Client with a detailed layout of all the connections to the networks and for the laying of the foundations. Prefabricated foundations are available and are delivered together with the toilet.

Usually, the works related to excavation, preparation of foundations and connections are entirely borne by the Customer, who carries out the work according to PTMatic instructions.

Once the foundations are finished, the toilet is transported on the installation site by a truck equipped with a crane.

The connections to the Municipal networks (water, sewerage and electricity) are then carried out by the Customer; a qualified PTMatic technician will then supply the toilet with all the consumable items (soap, disinfectant, toilet paper) and will start up the facility.

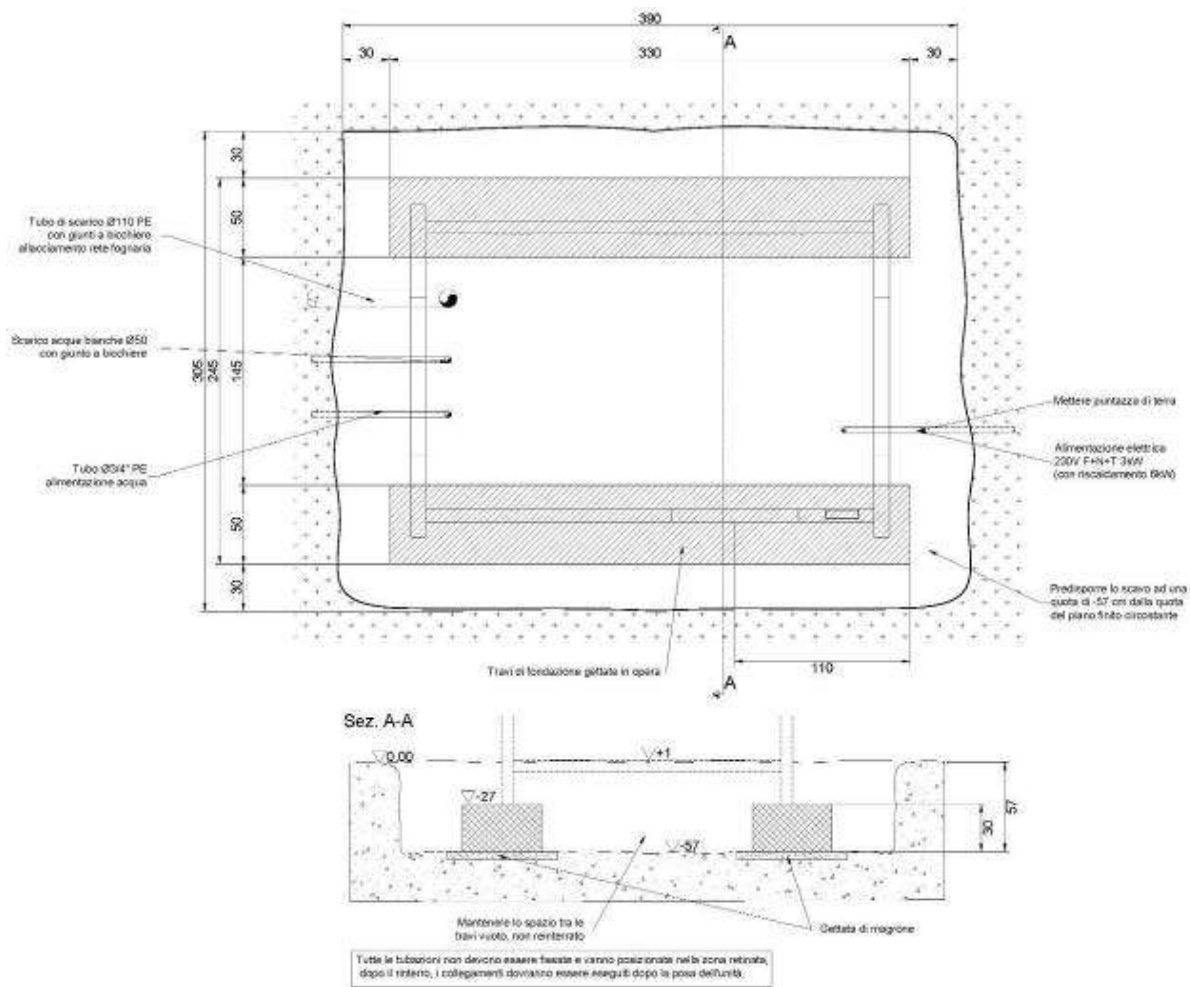

TMAX -Foundation drawing



## TECHNICAL SPECIFICATIONS

- **MONOLITHIC BOX-LIKE STRUCTURE: three-dimensional single block in reinforced concrete panels** (7-10 cm. minimum thickness), cover slab in flat reinforced concrete (8 cm. minimum thickness), shaped reservoir to convey meteoric waters. **The single block, obtained by mould, guarantees class S12 seismic resistance.** This feature allows safe and easy transport in case of displacement.
  - Upon request, walls can be thermally insulated with 3 cm polystyrene panels, embedded in the casting. Waterproof ceiling with bitumen-based and fiberglass sheath.
  - Ridge for meteoric waters with collection in single pipe union.
  - The gutter, connected to the unit's wastewater network, is placed in the technical room.
  - The single block is equipped with vertical connections to underground water, sewage and electric networks (with antifreeze safety system); this solution protects the toilet component from extremely cold temperatures.
  - External finish in smooth decorative beige concrete, with grey side abutments.
  - Other solutions (tile cladding, stainless steel panels, wooden panels or recycled materials) are available upon demand.
- **A LARGE GLAZED POLYCARBONATE AERATING-ILLUMINATING DOME**, square-based, 80 x 80 cm, placed on the top cover and mounted with special distance bars, ensures natural ventilation in addition to forced ventilation. Its shape and dimensions allow a correct natural lighting ratio and mitigates the feeling of being closed into a small place. The polycarbonate dome is mounted in an elevated position on the toilet's roof to create a sort of "chimney" that allows the natural recirculation of air should the automatic fan stop.
- **INNER HPL (HIGH PRESSURE LAMINATE) PANELS**, 13 mm. thick. Panels are made of cellulosic fibre sheets, impregnated with thermosetting resins; surfaces are smooth, scratch-resistant, free of cracks or crevices, fireproof and anti-mould. Walls are mounted on a stainless-steel structure, with no visible fixtures to prevent vandal acts and accumulation of dirt. The final finish is warm and welcoming, the light colour of the interior, the great quantity of light coming from the big translucent dome and the automatic lighting system create a wide and comfortable space. Walls are perfectly smooth, easy to wash, do not retain dirt and avoid accumulation of liquids.
- **CEILING TREATED WITH SYNTHETIC PAINT** with low resin content to guarantee breathability.
- **PTFLOO® FLOOR MADE OF SLIP-RESISTANT PROFILED RIBBED ALUMINUM**, manufactured according to our specifications, mounted on a stainless-steel load-bearing



frame. The frame is made of a rectangular section tubular structure in stainless steel to which the walkover flooring and the washing device are mounted. The floor is vandal resistant, with anti-cut and slip-resistant surface and under-lying collection system of wastewaters. These features avoid the need of periodic maintenance, mandatory for other solutions as rubber or PVC floors.

- **SLIDING DISAPPEARING DOOR**, with door frame in profiled stainless-steel sections, glued sandwich outside with a 15/10 thick satin-finish stainless steel sheet and internal 5 cm. of polyethylene insulation, AUTOMATIC low pressure safety opening/closing movement (1,5 atm) and high-pressure safety block (5 atm). The door leaf is a welded frame in tubular aluminium, containing a polypropylene honeycomb panel for thermo-acoustic insulation, covered on the outside and inside with anti-fingerprint finish stainless steel sheets, cold-bonded under press with polyurethane adhesive. The upper sliding rail is in aluminium and the rollers are equipped with silenced nylon wheels; the lower sliding rail is floor-embedded with no interruptions to prevent derailment in case of accidental impact.
- **TECHNICAL AREA ACCESSIBLE EXCLUSIVELY FROM THE OUTSIDE**, with vandal-proof door and two-point safety locking system. The technical room contains all the operation and management unit's equipment, so that maintenance can be carried out even when the toilet is in use. **Maintenance is possible also when the door is blocked** or if the cubicle has been damaged by vandals. All devices, equipment and circuits of the various systems that run the toilet are installed in the technical room. Maintenance and management of the unit to recharge tanks, remove coins, dispose of waste, regulate equipment can be performed without entering the cubicle. All waste pipes are in the technical room to be well protected and easily serviceable.

## INTERNAL FINISH AND EQUIPMENT

---

- **SUSPENDED CERAMIC BOWL** with rim at 80 cm. from the rear wall and axis at cm 40 from lateral wall. Stainless steel bowls are also available on demand. Both solutions are equipped with exclusive overflow security system, which verifies if the bowl is clogged: in this case, the toilet is automatically put in "out of service" mode. A stainless-steel version is available on request.
- **VANDAL-PROOF STAINLESS-STEEL WASHBASIN**, anti-syringe, with hidden drain and recessed syphon. The shape and the position of the washbasin allow safe and easy use; the automatic embedded cleaning system removes any object that could remain in the basin and conveys them in a bin installed in the technical room, inaccessible to users.
- **TOUCHLESS AUTOMATIC DISPENSERS OF WATER, SOAP AND HOT AIR** to dry hands, with automatically calibrated, microchip-controlled infrared rays. Pre-set soap delivery to avoid waste; all dispensers are protected and wall-recessed, inaccessible from the cubicles.



- **INNER WALLS** are stainless steel structures clad with 13 mm thick **high-pressure laminate** (HPL) panels. The panels are Class 1 fireproof and are made of cellulosic fibres sheets impregnated with high-temperature pressed thermosetting resins, to obtain perfectly smooth, scratch-proof, crack-free and easy to clean surfaces. The walls are fireproof and do not show any visible joint. The surface is smooth and does not show any gap.
- **INNER LIGHTING:** Cubicles are lit by natural light through the dome, and by artificial light with LED strip modules; an emergency lighting system is also available and is supplied by a backup battery (UPS). This grants a relevant cut in energy consumption, which makes the unit eco-friendly and able to convey a better inner lighting when compared to traditional solutions.
- **HANDGRIPS FOR DISABLED** in galvanized zinc-stainless steel, in shiny stainless-steel finish.
- **TOUCHLESS** internal control buttons, to control the flush, toilet paper distribution, opening of the door (from the inside)
- **STAINLESS STEEL UNBREAKABLE MIRROR.** A large unbreakable safety mirror is placed above the washbasin, at a height suitable for disabled users in wheelchair. Made of AISI 304 stainless steel with type 7 shiny mirror-like finish, with 53 x 80 cm approximate size.
- **STAINLESS STEEL COAT HANGERS** placed at suitable height for disabled users in wheelchair
- **STAINLESS STEEL WASTE BIN,** fireproof and smoke-resistant, completely wall-recessed and equipped with a big door. The 12 litres waste bin is equipped with a handle and can be removed only from the technical room.
- **AUTOMATIC DISPENSER OF TOILET PAPER\*:** vandal-proof, recessed and equipped with stainless steel chute, touchless button for toilet paper supply and low level/out of paper indicator.
- **EXTERNAL VANDAL-PROOF INFO PANEL.** The base version is equipped with a touchless button for the free use and a large LCD display with operating instructions in 4 languages (that can be chosen on request) and out-of-order warnings. A multi-coin or contactless card reader (fit for credit cards, id-cards or similar) are also available upon request. The display panel is a highly resistant vandal-proof, stainless-steel structure, recessed in the external wall and cannot be opened from the outside. **It is not possible to open the cash box from the outside.** The electronic cash box is programmed to accept up to 12 type of coins, is installed on the back of the panel. Coins are introduced in the coin-slot and conveyed into a collection box installed in the technical room. Another slot returns non-acceptable coins. The LCD display is equipped with three emergency optical and acoustic warning lights – “VACANT”, “OCCUPIED” and “OUT OF ORDER”- connected to an acoustic and optical alarm, vandal-proof and not visible from the outside, installed inside of the unit. *A new large full colour display will be available soon.*





## EQUIPMENT

---

### WATER SYSTEM

---

State-of-the-art manufacturing with components and equipment by leading brands: water system with “lack of water” control and electrically activated flush tank.

- **STAINLESS STEEL WATER TANK (60 litres)** Water tank equipped with “lack of water” control. A water tank guarantees flushing before putting the toilet in “Out of order” mode.
- **DISINFECTANT LIQUID TANK** with “minimum level” detection device and dosing pump.
- **MULTISTAGE CENTRIFUGAL WATER PUMP** in stainless steel with 80 l/min flow and 0.55 kW engine.
- **FITTINGS** in bronze and electro-valves supplied by leading brands.
- **ECO-FRIENDLY SAFETY BACKFLOW PREVENTER**

### PNEUMATIC SYSTEM

---

The pneumatic system manages all moving parts. A low-speed compressor supplies air pressure, while a 25 liters air reserve guarantees several openings/closings of unit’s door in case of power cuts.

- Pneumatic panel with compact modular valve unit with manual command; timer for automatic reclosing of door in case of power cut; pressure reducer with very low-pressure circuit for door closure and high pressure for door blocking system.
- DIN-ISO certified pneumatic translation units for opening/closing of toilet’s door, opening and closing of the door to toilet washing system, opening/closing and forward/backward movements of the door to Lava;-Tergipavimento® system.
- RILSAN-coated pipes connections and mechanical joints.

### ELECTRIC SYSTEM

---

Conceived in compliance with current regulations, with EC-type approval certificate by accredited certifying agency.

- **SINGLE-PHASE 230 V POWER SUPPLY** with 3kw power consumption.
- **ELECTRIC PROTECTION AND CONTROL PANEL BOARD**, equipped with DIN 0.03A differential switch and microprocessor for computerized management of all user-related



operations and toilet washing. The microprocessor can modify working hours, price of use of toilet, amount of time available for the user; quantity of disinfectant, toilet paper, duration of floor wash.

- **OPERATING LOGIC** carried out by PTMatic own microprocessors and specially developed electronic boards for the automation of the units
- **FORCED VENTILATION** with automatic start for air renewal in cubicle (about 45 changes of air per hour). Low noise, high flow centrifugal fan.
- **CYCLE COUNTER** mechanical and electronic. The mechanical cycle counter is non-resettable and counts the number of users. The electronic cycle counter, with display installed on the electric board, shows partial and total uses (e.g. between maintenance operations).

### DISPOSAL SYSTEM

---

- Closed-loop system with self-extinguishing polypropylene pipes, equipped with connecting sleeves and dual lip gasket in elastomer or weld beads.
- Two connections to sewage network: one for underfloor water collection system and one for toilet wastewater. All pipes are in the technical room and completely checkable.
- All pipes are in the technical room and completely reachable

### HEATING/EMPTYING SYSTEM

---

Includes:

- Electric 850w fan heaters in stainless steel with protection from possible water splashes. The design and installation of the fan heaters ensure the best hot air circulation in the technical room and the cubicle (if requested).
- Ambient thermostat installed in the technical room
- The size of the heating system maintains the temperature of the technical room above 5 degrees Celsius to protect the water system against freezing.

#### EMPTYING

- The emptying system protects the water system against freezing in case of fault of the anti-frost system or in case of power cuts.
- In case of extremely cold temperatures or lack of power, the device automatically empties the plumbing system and puts the unit in “out of order” mode. When the critical conditions are over, the unit starts functioning again and the system puts the toilet in “free” mode.



## SAFETY

---

The toilet is equipped with exclusive PTMatic special technology systems, which guarantee maximum safety to users and maintenance staff.

## USER DETECTION SYSTEM

---

**WEIGHT CONTROL.** The system is easy to calibrate and monitor the weight of the user to prevent the door from closing in case of presence of children, allowing in any case the use of the toilet.

The user detection system is vandal-proof and equipped with electronic weight sensors (stainless steel load cells), which **detect the weight (<1 Kg. tolerance)** all over the floor surface. It is possible to calibrate the threshold level (desired weight) with the programming keys installed on the unit management electronic board or by the remote-control system.

The system is programmed to allow the use of the toilet by children **but not by more than one user at a time:** if the weight exceeds the pre-set value, the toilet enters the Emergency mode activating its optical and acoustic warning lights.

## PNEUMATIC SLIDING DOOR

---

**AUTOMATIC SLIDING DOOR,** controlled by pneumatic system. A pneumatic automatic actuator, which **functions also in case of power cuts** thanks to a dedicated air reserve, controls all door movements. In case of total unit failure, users can activate the pneumatic circuit by simply pressing a push button, to open the door. The door is equipped with a **safety rubber profile to prevent crushing, squashing or injuries.**

Anti-crushing safety guaranteed by:

- ✓ **Very low-pressure supply to cylinder** during **door closure** (<1 Atm) and **final door lock at 5 Atm.**
- ✓ Highly sensitive electric profile with continuous contact installed on the door leaf, which reverses the door direction in case of an obstacle during the closing process. Unlike pneumatic profiles, the electrical profile operates even in case of cuts or punctures of the rubber.

The system guarantees door opening from the inside of the toilet also in case of:

- ✓ **Lack of power:** the opening push button installed next to the door, ergonomic in shape and size, guarantees automatic opening in case of power cuts, or manual opening in case of failure of the pneumatic system.



- ✓ **Sudden faint of the user** (unable to use the EXIT/EMERGENCY push buttons): the door opens automatically after 15 minutes from the start of the "Busy" mode and remains open until the user leaves the toilet. The automatic opening command also activates an optical/acoustic EMERGENCY signal.

## ✓ PT-LINE

---

**UNIT REMOTE CONTROL SYSTEM** for continuous monitoring of the toilet operating status by e-mail, via data network, to computer supervision system and to maintenance technician's mobile phone: activated in case of out of order, alarm or poor stock/lack of supplies. The system can give commands to the SIA and collect real-time data on its activity. An application package allows data processing and calculates statistical and chronological data.

The device constantly monitors the state of the toilet (on service/out of service/maintenance) and allow to give commands to the SIA:

Open/close door

Reset

It's possible to modify also some program data as:

Working time;

Price;

Turn off/ turn on external lighting

Recipients of messages can be diversified according to specific types of expertise, including:

- Short supply message→cleaning staff
- Maintenance message→maintenance technician
- Emergency message→Emergency service and/or security.

The system can send commands to the SIA and collect real-time data on its use. The management software, easy to access from our web-site [www.ptmatic.it](http://www.ptmatic.it) in the section "Services->Remote control", allows data processing to produce statistical and historical information.



## PT-CALL

---

Emergency communication system for users, via GSM/GPRS network, connected to the supervisory control room's phone: in case of emergency or necessity, the users simply has to push a button to be connected to our assistance centre. The system also allows the assistance centre to open the unit's door.

## WASHBASIN WITH SHARP-PROOF SAFETY SYSTEM

---

- Stainless steel washbasin with patented special design equipped with an automatically controlled nozzle installed in the bowl, which cleans and disinfects perfectly the washbasin after each use.
- The system removes all potentially hazardous objects left in the washbasin, and conveys them to a special bin installed in the technical room, inaccessible to users.

## EMERGENCY PUSH BUTTONS (SOS)

---

- Two emergency push buttons in the cubicle activate the opening of the door and optical-acoustic emergency warnings. The push buttons are big and ergonomic; one is placed next to the toilet, the other one is installed on the opposite side, at floor level, to help users lying on the floor.
- The push buttons work also in case of power cuts and open the door even in case of faults of the pneumatic system.

## EMERGENCY LIGHT

---

In case of power cuts, the emergency lighting systems switches itself on automatically and guarantees lighting for 120 minutes.

## FIREPROOF AND VANDAL-PROOF INDOOR COMPONENTS

---

All inner fittings are designed to reduce possible acts of vandalism; the washbasin, waste bin and toilet paper dispenser are recessed in the HPL walls. All parts that could be subject to vandalism are in the technical room and can be accessed only by authorized technicians.

All materials employed (HPL, stainless steel) are highly flame-retardant and smoke-proof: the mirror is made of shiny mirror-like finish stainless steel, extremely impact-resistant.

## USAGE TIME LIMIT SYSTEM

---

**Time limit system for users** with alphanumeric electronic LCD display indicating the remaining time still available and automatic door opening after time-out, signalled (3 minutes before) by optical-acoustic warning; time limit and warning are easy to program on the unit's electronic management board. At the end of the pre-set available time (usually 15



minutes), the time limit system warns the user and opens the door of the toilet, preventing misuse of the toilet and allowing rescue operations in case of sudden illness of user.

## PT-HELP

---

Vocal assistance messages with instructions for toilet use and indications on installed accessories, to support visually impaired users. The system communicates via pre-recorded messages about the toilet, e.g. door status, open, opening, closing, close, where the toilet bowl is, the position of the washbasin etc., and other useful information.

## PT-HEALTH

---

PTMatic self-cleaning toilets have been designed and built-in order to supply cleaning and disinfection after every use and the wash basin is equipped with touchless dispensers for water, soap and hot air, to prevent any contact, nevertheless an additional kit has been conceived to enhance the hygiene level and guarantee a highest safety degree to all users. This Kit complies with the guidelines of the ISS/WHO (**Ad interim provisions to prevent and manage the indoor environment in relation to the transmission of the infection by the SARS-CoV-2 virus. Version of March 23<sup>rd</sup>, 2020.**)

PTMatic PT Health embodies several devices to guarantee an improved sanitizing of the toilet room and prevent any contact with the surfaces.

1. PTMatic self-cleaning toilets are equipped with **sensors** that control the dispensers of water, soap, and hand-drying air, to wash hands thoroughly avoiding any contact with the surfaces.

Water is supplied for the time enough to guarantee the prescribed washing.

2. PTMatic toilets have been designed to ensure a complete washing cycle for wc-bowl and floor after every use, with a dilution of SESTENE (a quaternary ammonium salts-based product) in water (already tested in the past).

This mix in the new kit may be replaced by **XIDENE**, a more aggressive **disinfectant** and fungicide containing tetradecyl dimethyl benzyl ammonium chloride, chlorhexidine and ethyl alcohol (0.8% in water).

3. The **IR buttons** (available as standards) activate from a distance the opening/closing of the toilet door, but also the toilet paper dispenser and the extra-flush (when installed)





The sensor is calibrated in order to ensure an activation gap enough to perform the operation required but preventing accidental activation of the IR button (e.g. with clothes or bags).

4. The disinfection cycle performs the following operations:
  - Deactivation of the axial intake fan
  - Activation of the UVc lamp (the lamp turns on when the toilet is "vacant")
  - Re-activation of the axial intake fan

When a user opens the door to use the toilet, the cycle interrupts.

5. **UVc Lamp.** UVc lamps are already frequently used thanks to their anti-bacterial properties and guarantee the sterilisation of surfaces through irradiation





Specifically, as attested by the study "*UVC irradiation is highly effective in inactivating and inhibiting SARS CoV 2 replication*", carried out by a team of physicians and astrophysics from Milan *Università degli Studi* (department Luigi Sacco), of the *Istituto Nazionale di Astrofisica* – Inaf (National astrophysics institute), and *Istituto Nazionale dei Tumori* (National Institute for Tumours), UV-c rays, even in small dosage, are active on SARS-Cov-2 virus, inactivating its viral charge by 99.9% in few seconds.

The UV rays at specific wave lengths (253,7 nm) *destroy molecular bindings* of the micro-organism's DNA and of the viruses' RNA making the harmless and inhibiting their proliferation.

The lamp is programmed to switch on when the toilet is "free", thus sanitizing the user room between a use and the next one, so that people are not exposed to it.

6. Implementation of the already existing ventilation system adding an axial intake fan. Wall axial intake fan are already implemented on PTMatic toilets and ejects air directly outside. The ball-bearing motor installed allow to use it also for a long period thus guaranteeing the possibility to extract air during the whole service cycle of the toilet – the toilet is normally switched off at night. Furthermore, the technical data sheets *suggest a capacity of 100m<sup>3</sup>/h in order to ensure a complete air exchange every 10 minutes.*
7. Installation of **PT-HELP**: sound diffusion system with voice messages for visually impaired users





## PLUS TECHNOLOGY®

---

Management, cleaning and disinfection PLUS® technology guarantees a perfect wash, disinfection and drying of toilet: it is a combined patented system that washes and dries the toilet seat, then washes and dries the floor, removing all debris thanks to the patented shifting system Lava;-Tergipavimento®.

### MAIN FEATURES

---

1. Automatic wash and disinfection:
  - Micro-flush coating of the bowl while in use;
  - Automatic flush of the bowl after use, wash and disinfection of bowl, drying of bowl top;
  - Washing and disinfection of the toilet walls up to a height of 0,8 m around the bowl and washbasin;
  - Washing of washbasin with high-pressure nozzle;
  - Scouring of floors with shifting system for mechanized removal of debris; washing, disinfection and drying of floors with Lava-Tergipavimento® technology, patent nr. MI 2005 A001873.
  - The entire toilet is washed and DISINFECTED by silver hydrogen-peroxide spray during night-time closure with special DCN-ECO3® cycle (upon request)
2. Accurate detection of the presence of a user in the unit:
  - Special electronic weight sensors determine with extreme precision, and tolerance of less than 1 kg, the presence of children, adults or more than one user, guaranteeing a targeted safe use of the facility and preventing misuse.
3. Maximum safety for users:
  - All moving parts are pneumatic and the door opens and closes even in case of power cuts.
  - The washbasin is shaped to prevent the presence of hazardous objects (syringes or other) in the bowl.
  - There are no sharp edges or joints; all surfaces are designed with careful attention to ergonomics.
  - PT-Call® : two-way emergency call system



## WASH AND DISINFECTION SYSTEM

---

### WASH, DISINFECTION AND DRYING OF TOILET BOWL

---

Washing, disinfection and drying of toilet bowl are performed in the cubicle, when the user is not present.

The washing nozzles, installed on a door-mounted device that slides horizontally over the toilet seat, spray a blend of water, disinfectant and air.

Toilet bowl wash and disinfection are carried out while the door is opening; drying of toilet bowl is carried out while the door is closing.

The toilet bowl is subject to three types of wash:

- ✓ Micro-flush coating of the inner walls of the bowl while in use: prevents “adhesions” to walls and facilitates the next wash.

*Duration: time of use of the toilet.*

- ✓ Automatic flush after use, with a 6 liters blend of water and disinfectant delivered under pressure by high-pressure stainless-steel pump and discharge into sewage network

- ✓ Wash of the inner walls of the bowl (flush) through the internal flush-holes.

*Duration: 6 sec.*

*Used blend: 6 liters approx.*

*Pressure: 2 bar*

### WASH OF TOILET SEAT AND WALLS:

---

Wash by pressure waterjets with a blend of water and disinfectant delivered by nozzles mounted on a rotating device. The movements of the rotating device, the angle of inclination of the waterjets and the high pressure of delivered water obtain a “chisel effect” which makes the wash cycle particularly efficient.

### DYNAMIC WASH OF THE TOILET SEAT

---

5 high-pressure nozzles deliver jets of water mixed with disinfectant: an opening hinged door mounted on the toilet's upper edge is equipped with a wastewater collector and a dryer. The special door movement gives the wash cycle a special “CHISEL” effectiveness.

*Duration: 20 sec.*

*Sprayed blend: 3 liters*

*Pressure: 6 bar*



**Drying of toilet seat** obtained by streams of pressurized air, generated by a tangential electric fan (560 cm/h at 500 Pa), through a diffusor that conveys and directs the airflow to obtain a "Coanda" effect that eliminates any water residue from the toilet seat.

Extremely effective, low noise and highly efficient electric fan.

### WASHING OF WALLS

---

A washing system cleans the walls surrounding the toilet bowl up to a height of 0.8 m. The system washes and cleans the walls that could have been soiled by users.

Nozzles mounted on the wall behind the toilet deliver pressure jets of disinfecting blend to wash all the walls. The nozzles are installed at a height of 80 cm. from the floor and their angle of inclination allow them to wash large surfaces.

*Duration:* 5 sec.  
*Sprayed blend:* 1 litre approx.  
*Pressure:* 3 bar

### WASH OF WASHBASIN BOWL WITH HIGH-PRESSURE NOZZLE.

---

An automatically controlled nozzle installed on the washbasin's inclined plane cleans and disinfects it effectively after each use.

The system removes all objects from the washbasin's bowl and conveys them to a stainless-steel bin installed in the technical room, inaccessible to users (anti-syringe safety). 1 nozzle installed in the bowl delivers pressure jets of disinfecting blend.

*Duration:* 5 sec.  
*Sprayed blend:* 0,5 litre approx.  
*Pressure:* 3 bar

### WASH AND DRYING OF FLOORS WITH LAVA;-TERGIPAVIMENTO<sup>®</sup>

---

Cutting-edge patented PTMatic system (patent n° MI2005 A001873), designed with proprietary technology, to re-establish the highest level of hygiene of the floor. To obtain this result, the system carries out 5 combined actions during its forward-backward translational movement.

The device is installed behind the lateral wall of the cubicle. A vandal-proof door opens automatically while another door, installed on the opposite wall, opens automatically to collect all the debris from the floor and stores it in a special bin.

The system consists of a horizontal bar, which has the same width of the cubicle and runs along the floor's major axis. **A pneumatic actuator switches on the bar.**



The **PTFloo**<sup>®</sup> floor is made of slip-resistant, fingerprint resistant and anti-bacterial profiled ribbed aluminum: this material has the advantage of being free of junctions or fixtures and does not need periodical maintenance. Wash cycle frequency is easily programmed according to the Client's needs and to the daily number of users.

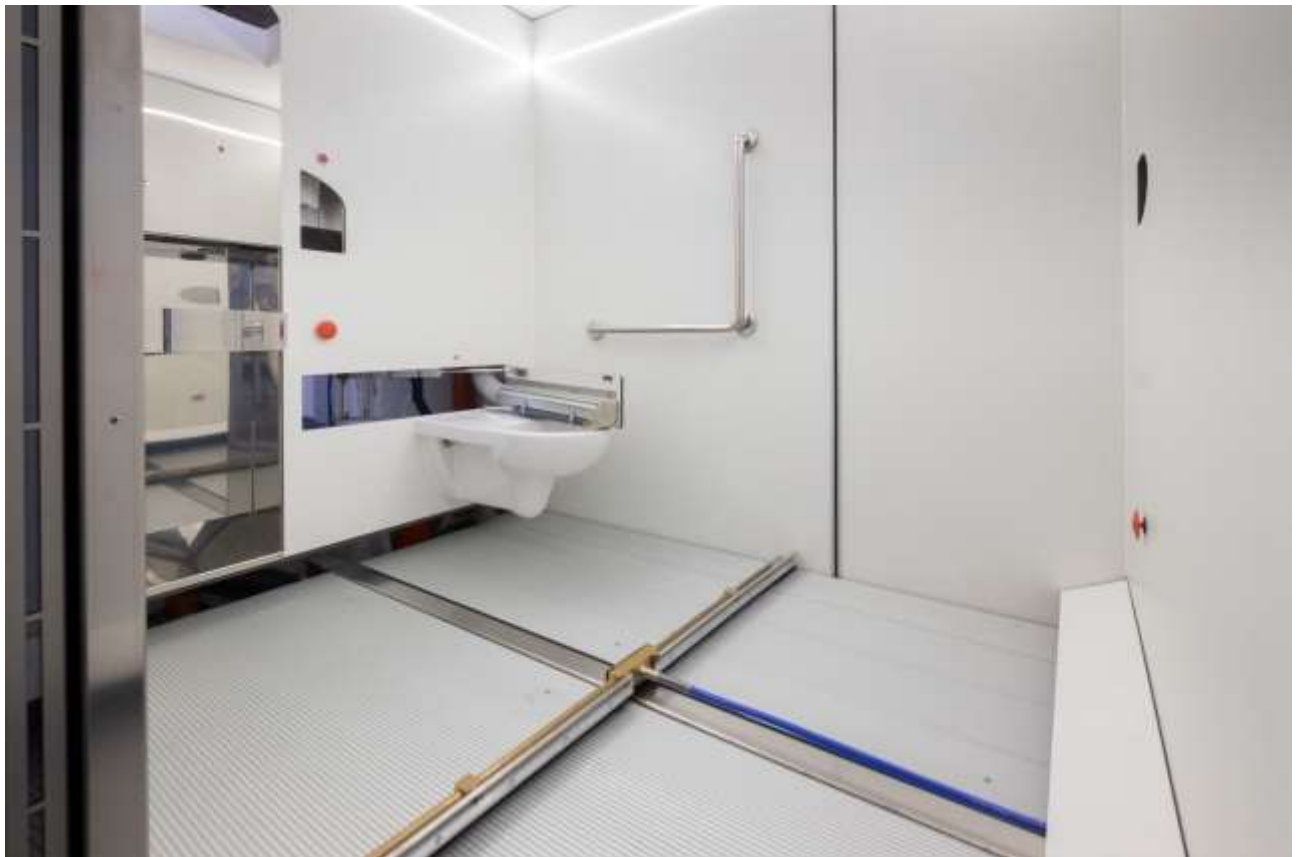

#### **FORWARD RUN – HIGH PRESSURE WASH**

The bar has 8 oblique nozzles that spray a high-pressure washing blend on the floor. The bar runs over the **whole floor surface** and guarantees a perfect wash and disinfection.

**Special self-levelling brushes** installed on the bar perform an action similar to a car's windscreen wipers.

✓ "SCALPEL EFFECT"

Jets of water and disinfectant wash the whole surface of the floor, removing all objects, including gravel, soil etc.

✓ "COLLECTION EFFECT"

The bar "pushes" mechanically objects and/or waste, such as cans or glass bottles, which are particularly dangerous if broken, waste paper, newspapers, nappies, waste, soil, syringes, and conveys them into a special bin, up to the size of a 1,5 litre plastic bottle.



✓ "FIRST SCOURING-DRYING EFFECT"

Waste on the floor is removed by "push action" thanks to the special brushes, which take away waste and/or objects particularly adhering to the floor surface (e.g. chewing gum, cellophane, wet paper). First removal of liquids from the floor.

**BACKWARD RUN - TOTAL DRYING**

✓ "SECOND SCOURING EFFECT"

Completion of floor scouring cycle with removal of waste still present on the floor.

✓ "DRYING EFFECT": removal of remaining washing liquids. The floor is completely dry, with no water drops or puddles.

A light residual film of disinfectant blend guarantees a continuous sanitization process.

The **Lava;-Tergipavimento** guarantees the highest level of cleaning and hygiene also when the floor is particularly dirt, any waste remained on the floor can be removed by the same washing system.



### **PERFUMING SYSTEM PT FRESH®**

---

Automatic fragrance system with special PTMatic device, which contains a spray canister available in several fragrances and easy to replace.

The device is activated automatically when a user enters the unit and sprays a pleasant and persistent fresh, clean scent.

### **NIGHT-TIME TOTAL DISINFECTION CYCLE- DCN-ECO3®**

---

In collaboration with several companies in charge of medical waste-disposal and hospital sanitation, PTMatic has developed an innovative device for the total disinfection of toilets.

The system uses water or low-percentage disinfectant blends to wash the toilet, so that all waste liquids (excluding wastewater from the toilet) are completely free of polluting agents and can be released in the environment or recycled for irrigation.

A generator disinfects the WHOLE toilet (also areas not directly subject to washing) by vaporizing the disinfectant in the cubicle with a dry mist of silver hydrogen peroxide.

The cycle is microprocessor-controlled and saturates the cubicle with silver hydrogen-peroxide disinfectant for the time needed to disinfect completely the cubicle and dispose of all the disinfectant. The cycle eliminates all viruses, bacteria, spores, mites and insects.

The device prevents fungal or mould growth that usually occurs in damp environments, especially in areas that cannot be reached by normal washing or manual cleaning (e.g. hidden parts of the aerating-illuminating dome or remote corners), and leaves a light pleasant fragrance in the cubicle.





## CYCLE OF USE

---

When approaching the hand to the touchless control installed on the external panel (or inserting a coin in the cash box in case of entry fee) the following functions are activated:

- ✓ Lighting of the toilet;
- ✓ Automatic opening of the door;
- ✓ Time limit display/device
- ✓ "Busy" signal on info-panel;
- ✓ Increase of one unit on cycle counter;
- ✓ PT-help: sound diffusion system with vocal instructions and messages for low vision users (if installed);
- ✓ Micro-flush coating of the toilet bowl;
- ✓ Fresh air supply fan;
- ✓ Touchless automatic dispensers of water, soap, hot air and toilet paper;

When a user enters the toilet, the user detection system verifies the user's weight and modifies the toilet's mode from "free" to "busy", activating the following functions:

- ✓ Inner illumination of the toilet;
- ✓ Automatic closing of the door (only if the detected weight complies with the pre-set);
- ✓ Safety and control systems;
- ✓ Count-down of maximum available time.

After toilet use, the user shall leave the cubicle.

If the same user, or another one, enters the unit before the door closes, the emergency warning (optical and acoustic) turns on.

When the toilet is vacant, a series of actions is activated:

- ✓ The door closes;
- ✓ Lights are turned off;
- ✓ Micro-flush coating of the toilet bowl stops;
- ✓ Music stops (if supplied);
- ✓ Safety systems are deactivated;
- ✓ Automatic dispensers are deactivated;
- ✓ Wash and disinfection cycle of unit turns on;
- ✓ The timer is reset



**At the end of the washing cycle, all components installed in the unit are tested before making the toilet available for the next user.**





## OPTIONS

KM50	<p><b>Kit Winter Pro</b> – heating increase system for use of unit in particularly severe climate; the kit includes:</p> <ul style="list-style-type: none"><li>✓ Comfort Plus Heating;</li><li>✓ Automatic emptying system of water system;</li><li>✓ Thermal and acoustic insulation of unit;</li><li>✓ Electric water heater.</li></ul>
KM51	<p><b>Kit INOX</b> – toilet accessories in vandal-proof stainless steel; the kit includes:</p> <ul style="list-style-type: none"><li>✓ Stainless steel suspended toilet bowl;</li><li>✓ Stainless steel baby-change table;</li><li>✓ Stainless steel grab handles</li></ul>
KM54	<p><b>PTHealth:</b> Kit conceived to prevent viruses and bacteria spreading and to implement disinfection systems.</p> <ul style="list-style-type: none"><li>✓ The floor and wc-bowl washing are performed with a mix of water and TDBAC, chlorhexidine and ethylic alcohol</li><li>✓ No-touch sensors to access and exit the toilet room and for toilet paper ejection</li><li>✓ UVC lamp to reduce the bacterial count</li><li>✓ Total air rechange at night through an axial intake fan</li><li>✓ PT-help-sound system emission with voice instructions and messages to users visually impaired.</li></ul>



## EQUIPMENT PROVIDED

### EXTERNAL FEATURES:

ACM14	<b>External energy saving LED lighting.</b>
ACMxx	<b>External finishing available on request (wood, tiles, stainless-steel)...</b>
ACM12	<b>Anti-graffiti</b> coating with shiny finish to protect the external of the unit.

### OPTIONS

ACM01	Frost protection <b>Safety Heating</b> with electric convection heaters (technical room).
ACM05	<b>Multi-coin cashbox</b> , installed on external signal panel, equipped with collection box and meter; it replaces the pushbutton for free use of unit.
ACM06	<b>Magnetic key/card reader.</b>
ACM07	<b>PT-Line-Remote control system</b> of unit with GSM transmission of information to mobile phone and/or computer.
ACM15	<b>DCN-ECO3®-night-time total disinfection system:</b> wash of the whole unit and nebulization of a disinfectant mix during night-time closure; the mix does not contain pollutants, and releases a fresh perfume.
ACM20	<b>Internal HPL walls customized</b> with images chosen by the Client.
ACM25	<b>Stainless-steel baby-changing table</b> , installed in the cubicle for users with disabilities.
ACM35	<b>Door to technical room in satin-finish stainless-steel.</b>
ACM69	<b>Prefabricated foundations</b> in Vibrated Reinforced Concrete (VRC) supplied with laying setup.
ACM75	<b>PTcall</b> -bidirectional emergency call system for users, via GSM/GPRS network, to the phone of the control room.

## TECHNICAL DATA SHEET

<b>Size</b>	3,04 m.x2,10 m. h: 2,60
-------------	-------------------------



<b>Weight</b>	8.500 kg
<b>Electric system</b>	
Connection to electrical mains without heating (or a/c)	220V F.N.3KW
Connection to electrical mains with heating (or a/c)	220V F.N.6KW
Minimum cross-section of power cables	6 mm <sup>2</sup>
Maximum voltage of earth-leakage circuit-breaker	0.03A
Electric commands and signals	5, 12, 24V
<b>Water system</b>	
Water supply pipe	Ø ¾"
Minimum pressure of water system	1,5 atm.
Wastewater pipe	Ø 110 mm.
Walkover flooring wastewater pipe	Ø 50 mm.
<b>Capacity of tanks</b>	
Water tank	litres 60
Toilet flush-tank	litres 10
Disinfectant tank	litres 10
Liquid soap tank	litres 3
<b>Consumption per wash cycle (excluding heating)</b>	
Water	Litres 16
Disinfectant	Cc.20
Power	20 W
Toilet paper (1 jumbo roll: 400 pieces)	Up to 99 pieces
<b>Duration</b>	
<b>Wash, disinfection and drying cycle</b>	55 seconds